

FREYA-LZ A (FuMG-401) "German field radar station" 1/48



HLS48002

První série nového radaru FREYA-LZ (FuMG-42G) firmy GEMA byla vyrobena v listopadu 1941. Základ konstrukce byl navržen ze standardizovaných dílů a jeho systém umožňoval časté a bezproblémové přemísťování. Celá radarová stanice byla napájena z externího generátoru o napětí 380V.

Novější verze Freya LZ dostala označení FuMG-401, a vyznačovala se pozměněnou konstrukcí a především větším dosahem. Luftwaffe používala úspěšně tento typ radaru v součinnosti s radary Wurtzburg-Riese a do konce války odebrala okolo 400 kusů všech verzí.

Dosah :30-200Km
Výška :cca 12 m

First series of new radar FreyaLZ(FuMG-42G) was produced by GEMA Germany in November 1941. The base of radar was designed as standardized construction for frequent change of location in battle area. Radar station was powered by external generator (380V).

Later versions of Freya-LZ were named FuMG-401. They were redesigned for longer distance.

Luftwaffe used successfully FREYAs in collaboration with Wurtzburg-Riese and before end of 2. WW got cca 400 units of all versions of FREYAs.

Distance:30-200Km
Height (cca):12m

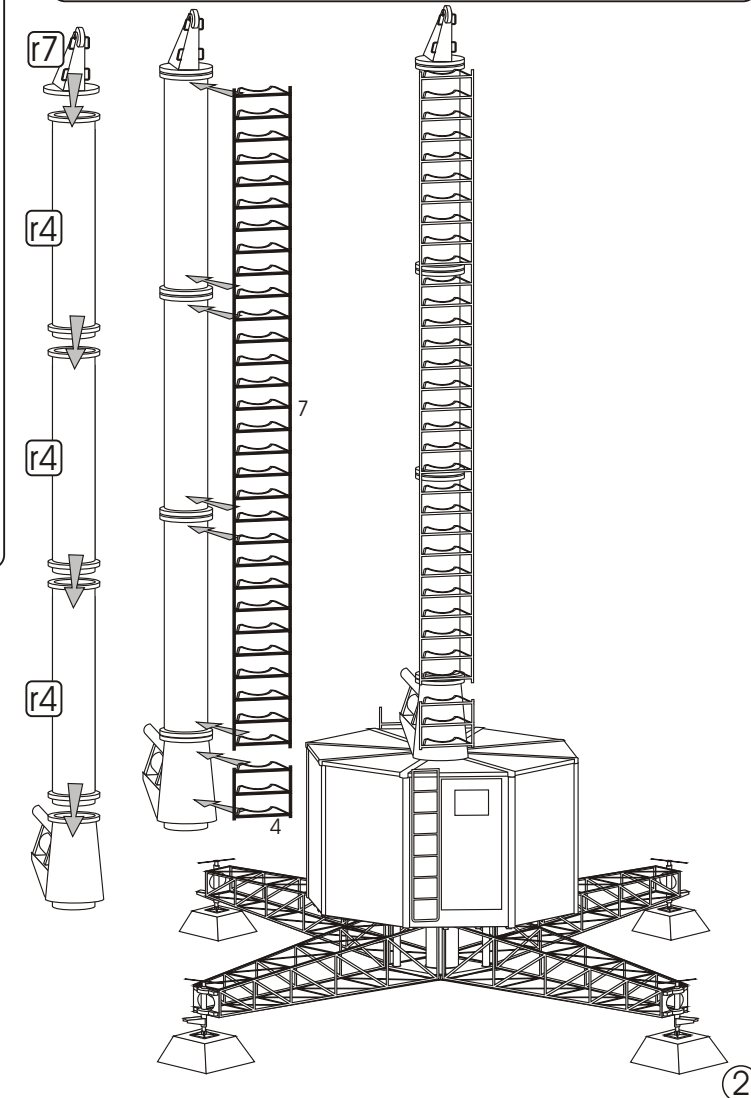
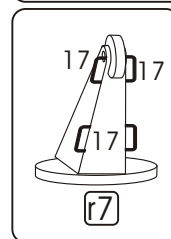
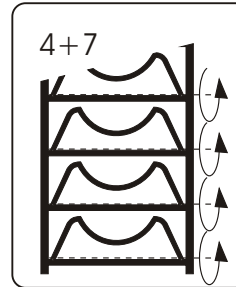
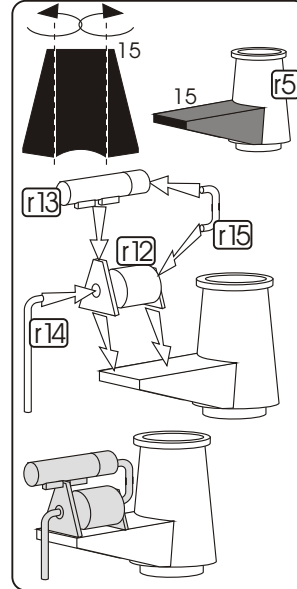
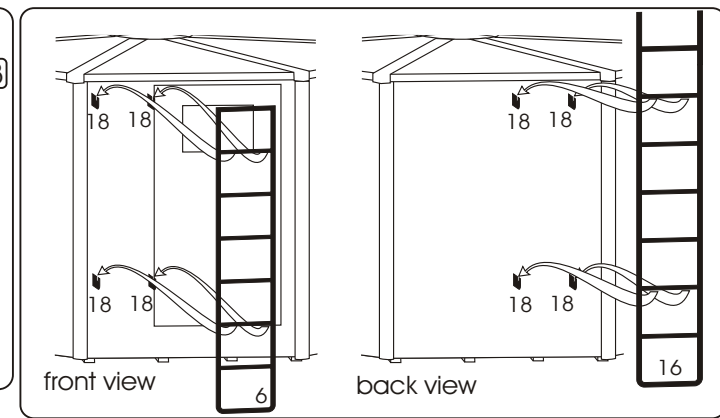
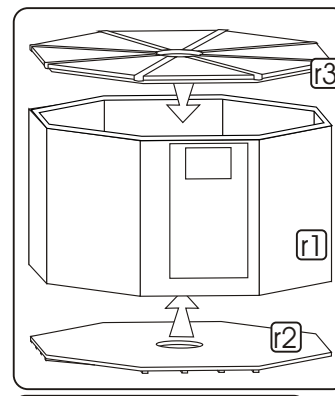
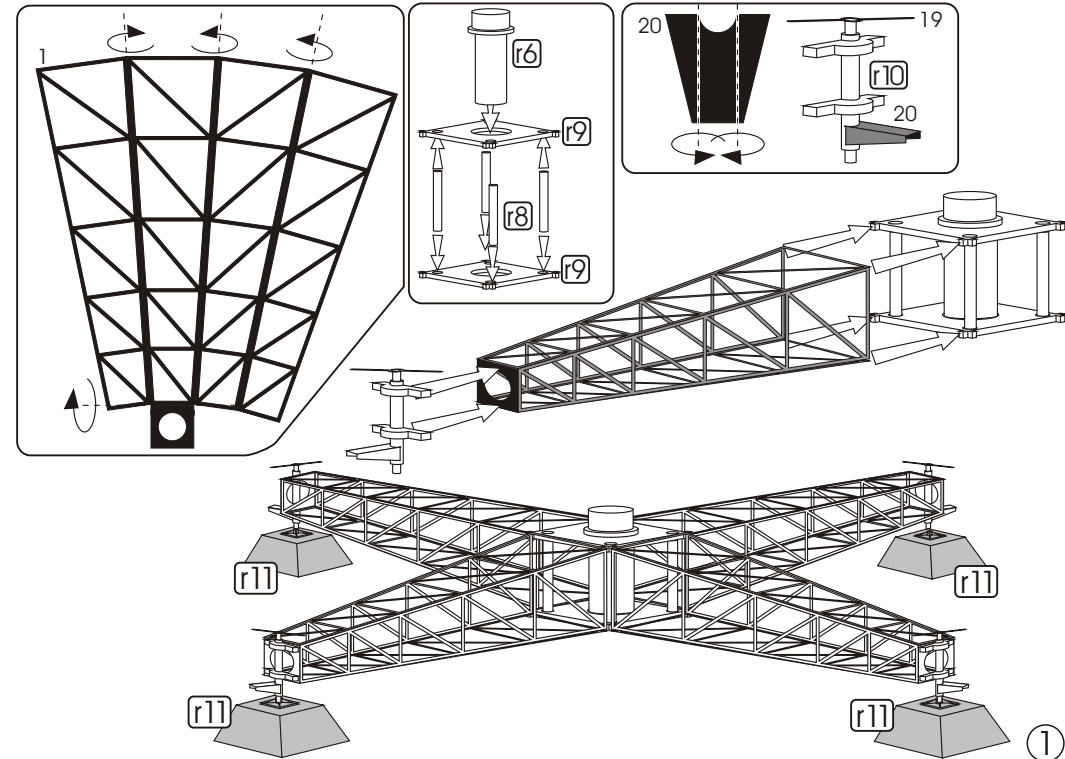
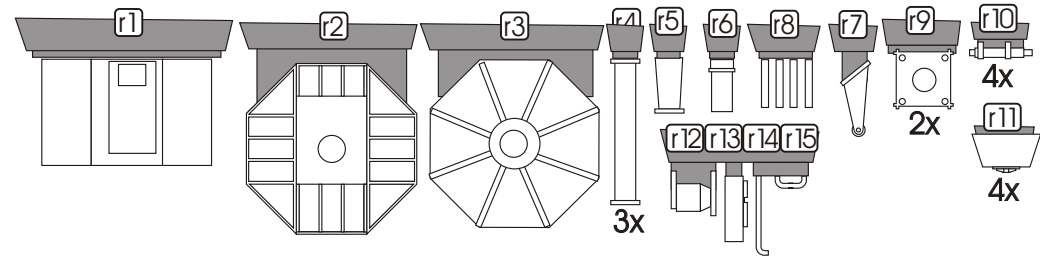

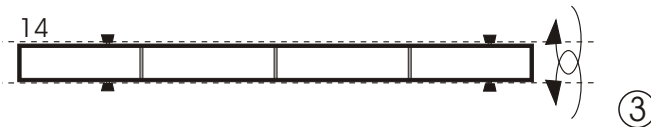
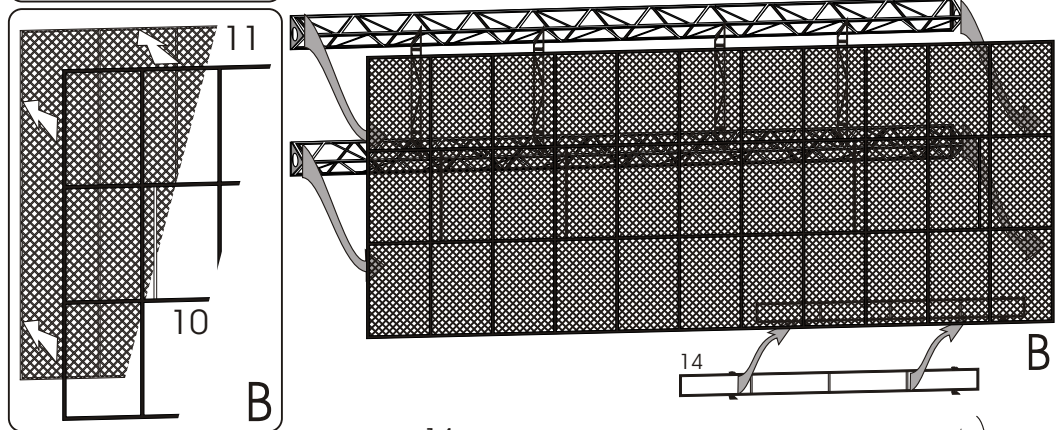
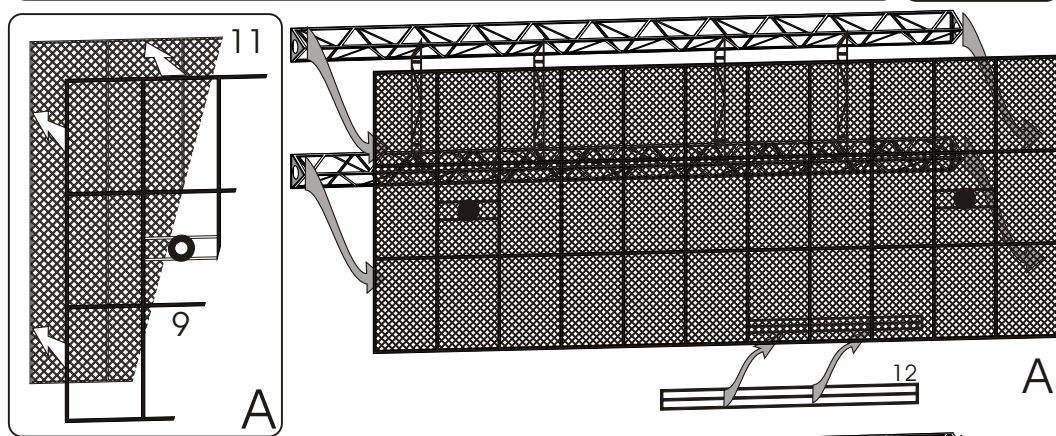
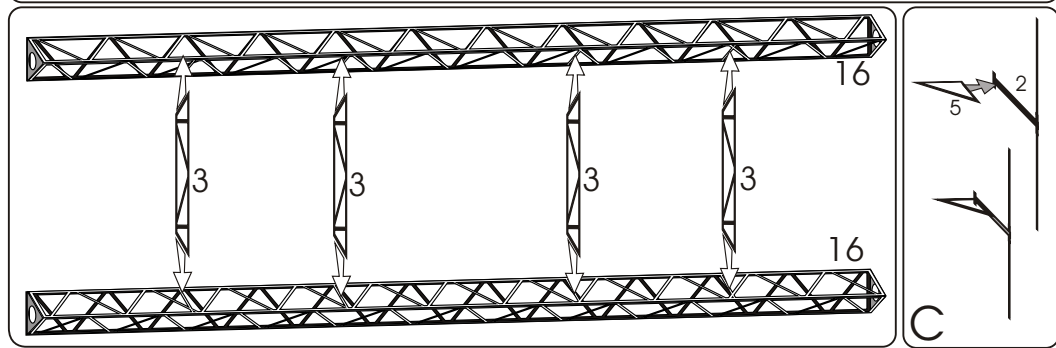
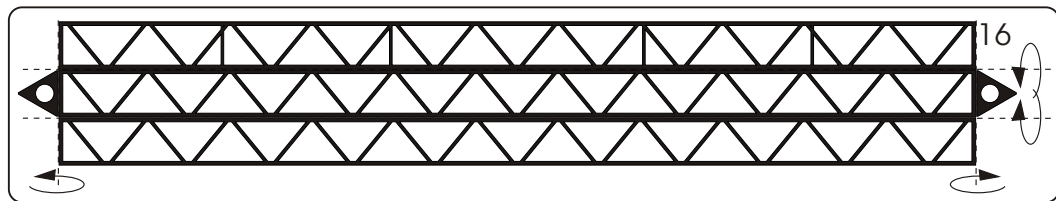

③

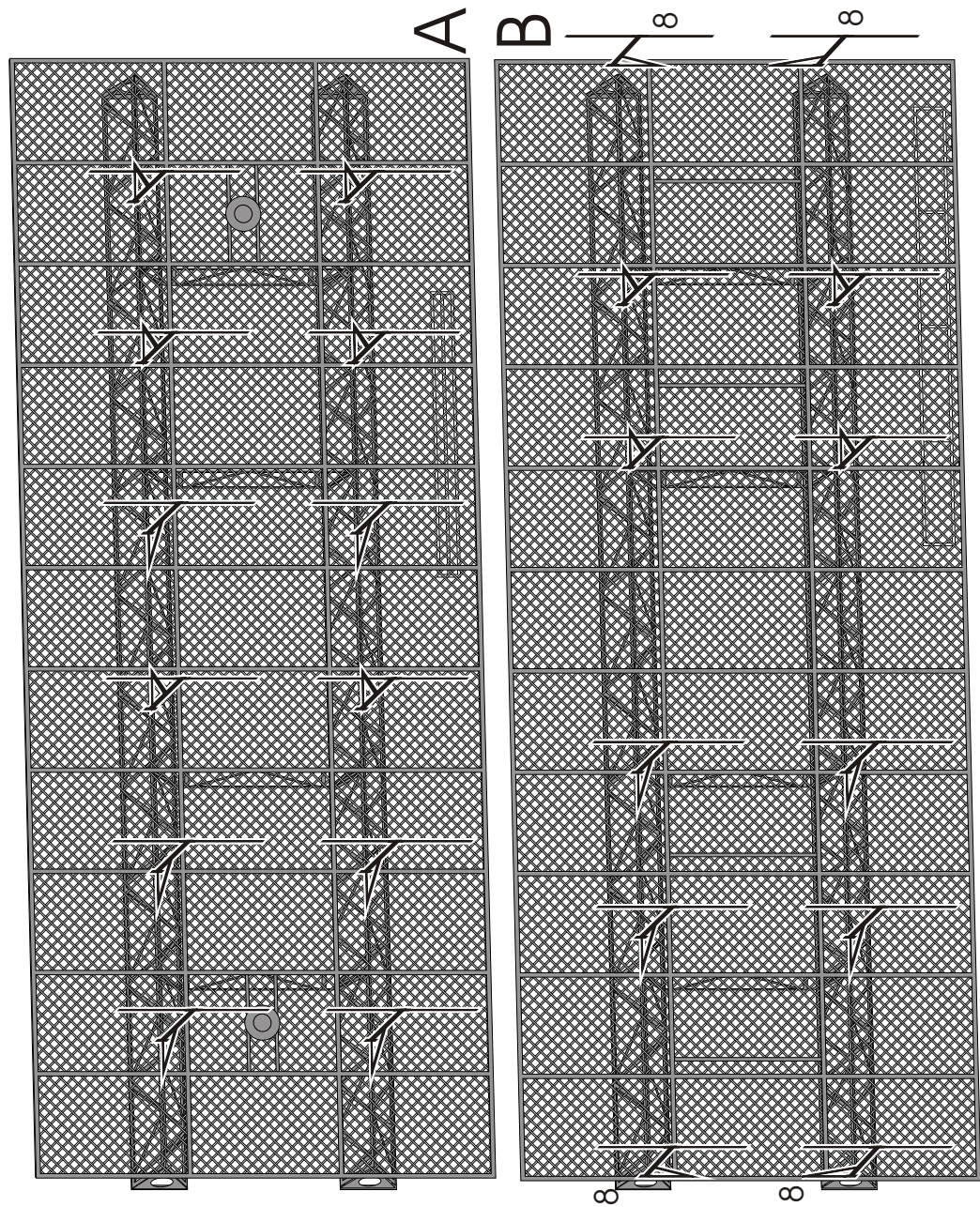

④

Position of antenna. Drawing out of scale.
 Pozice antény. Výkres mimo měřtko.

